



BRC 310-1000 BALANCE BAR ASSEMBLY

Bicknell balance bar assemblies allow precise adjustment between front and rear brake bias. They have been specifically designed for racing purposes. When properly set-up, this unit will give you the proper amount of bias adjustment. Always remember to keep the bar well lubed and free of debris. The bar should have approximately 1/4" of up and down movement. This means the bar can pivot freely without obstructions. It is also important to ensure the brake pedal returns to the relaxed position freely and that there is no pressure exerted on the master cylinder.

BALANCE BAR ADJUSTMENT

Thread the master cylinder pushrods into the clevises on the balance bar. A good starting point can be found in Figure 1. From the end of the clevis to the front side of the master cylinder mounting surface should be 3 3/4" for front and 4" for the rear in a typical dirt car set-up. The balance bar should be straight up and down under moderate pedal effort (Figure 2). This may lead to the balance bar being cocked under no pedal effort. This is perfectly fine as long as there is NO pressure on the master cylinder push rods when the pedal is in the relaxed position.

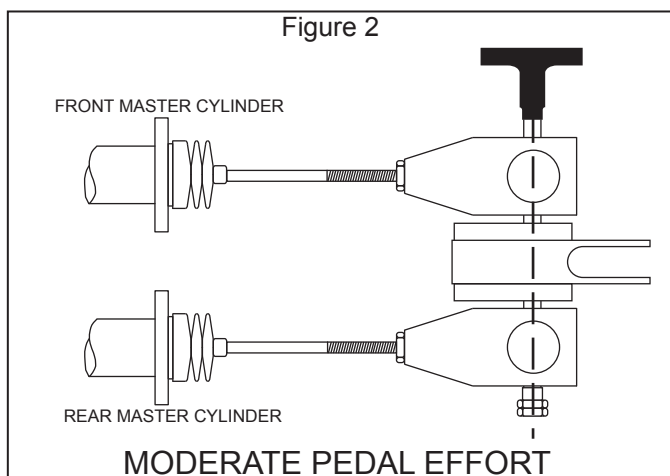
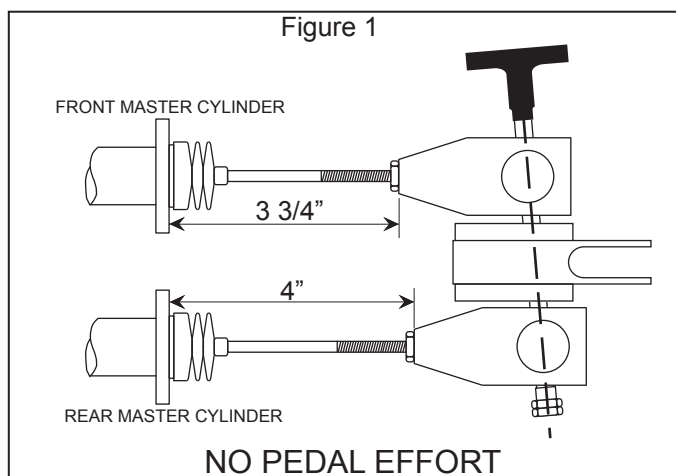

Please note: the above pushrod adjustment is for a typical dirt application with small front calipers and large rear calipers. Master cylinder size and caliper size have a large effect on the adjustment. If you have any questions, please call 905-685-4291.

In the neutral position, the balance bar should have approximately 1/4" of play between the clevises (figure 3). If there is too much play the master cylinder pushrods will be at the incorrect angle as shown in figure 4. The clevises should be set from the factory, but should be double checked to ensure they are in the correct location.

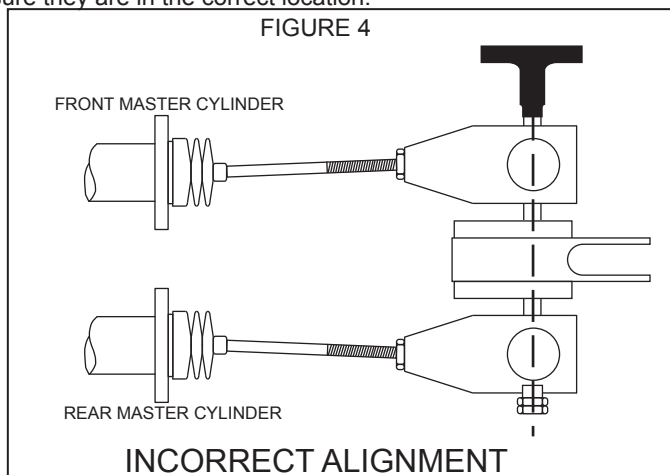
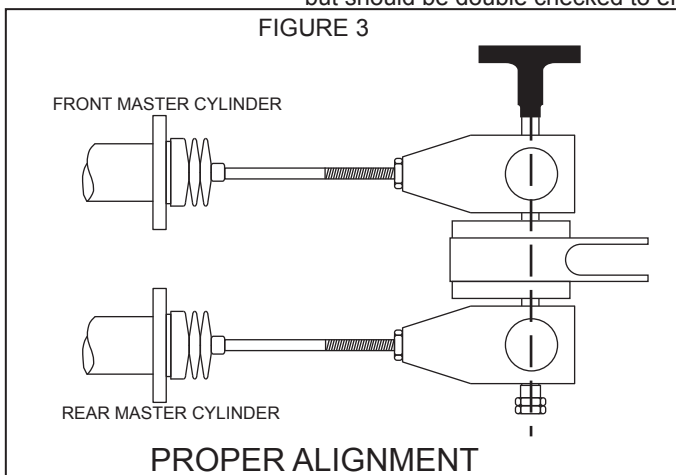

IF YOU HAVE ANY QUESTIONS, PLEASE CALL THE TECH LINE AT 905-685-4291